

Management system as per  
执行以下标准

GB/T 19001-2016 / ISO 9001: 2015



ENGEL MACHINERY (CHANGZHOU) CO., LTD.  
No. 9 Longfan Road, Wujin National Hi-Tech Industrial Zone,  
Changzhou 213166, Jiangsu Province, P.R. China  
tel: +86 519 8159 5300  
fax: +86 519 8159 5388  
e-mail: info@wintec-machines.com

恩格尔注塑机械（常州）有限公司  
中国江苏省常州市武进国家高新技术开发区龙帆路9号  
邮编：213166  
电话：+86 519 8159 5300  
传真：+86 519 8159 5388  
邮箱：info@wintec-machines.com

2023\_03\_GB\_CN/EN

**WINTEC**  
MEMBER OF THE ENGEL GROUP

t-win

HYDRAULIC TWO PLATEN INJECTION MOLDING MACHINE

t-win液压二板注塑机



# Production Locations 全球工厂



—  
 Located in Changzhou, Jiangsu Province, China, WINTEC is the second brand established by ENGEL Group in 2014, insisting on high quality products and reliable services for the commodity segment of injection molding. After several years of sustainable growth and continuous development of our portfolio, WINTEC has completed the global rollout by adding Europe in 2021. The worldwide sales and service network of the ENGEL Group provides you with high quality injection molding machines for standard applications while ensuring fast and effective after-sales support.

—  
 赢泰位于中国江苏省常州市，是ENGEL集团于2014年创立的第二品牌，坚持以高品质的产品和可信赖的服务为宗旨。历经数年的持续增长及产品组合的不断发展，赢泰于2021年开拓欧洲市场，自此完成了其全球推广的进程。遍布全球的销售及服务网络，为您提供高品质标准应用注塑机的同时，也确保了快速有效的售后支持。

## ENGEL GROUP

9 PRODUCTION PLANTS  
9 个生产工厂

30 SUBSIDIARIES  
30 个分支机构

60 REPRESENTATIVES  
60 个代表处







ENGEL, as the world's leading supplier of injection molding machines, represents stability and continuity in the industry. As a 100% owned subsidiary of ENGEL, WINTEC will spare no effort to create efficient and stable injection molding machines.

At the same time, WINTEC relies on the strength of its parent company and its comprehensive global sales and service network to provide fast and effective after-sales support while ensuring the quality of its products, making it a reliable partner for your successful international development.

ENGEL作为世界领先是注塑机供应商,是稳定性和持续性的行业代表。作为ENGEL的全资子公司,赢泰将不遗余力地打造高效稳定的注塑设备。

同时赢泰依靠母公司的雄厚实力及健全的全球销售及服务网络,在确保产品品质优良的前提下,能快速有效地提供售后服务支持,是您国际化发展进程上可靠的合作伙伴。

# t-win

## YOUR ADVANTAGES AT A GLANCE

### 优势一览

#### HIGHER PRODUCTIVITY

##### 更高的生产效率

The servo hydraulic two-platen t-win is focused on fast and high efficient production. Fast movements, short clamping force build-up time and synchronized locking device movement reduce total cycle time and increase productivity.

伺服液压驱动二板式t-win系列注塑机专注于快速、高效的生产。高速的运动，较短的锁模力建立时间及同步锁紧装置，降低了循环周期，提高了生产效率。

#### INCREASED AVAILABILITY

##### 更高的可利用率

The reliable and proven design as well as features allow fast access for maintenance and increase machine availability and output.

可靠且久经考验的设计加之稳定的性能，使赢泰注塑机易于维护，从而提高了机器的可利用率 and 产出。

#### SMALLER FOOTPRINT

##### 更小的占地空间

The two-platen machine concept allows a compact design for less space requirements.

紧凑的两板式设计为您节省占地空间。

#### HIGHER ENERGY EFFICIENCY

##### 更高的能源利用率

The servo drive system servowin guarantees fast acceleration and low energy consumption.

伺服驱动系统保证了机器的快速运转，降低了能源消耗。

#### LONGER SERVICE LIFE

##### 更长的使用寿命

Premium components and a design concepts that reduce wear on the machine – and on your mold – guarantee an extended service life of 15 to 20 years and more.

优质的元件及优秀的设计理念，降低了机器本身乃至模具的损耗，实现15至20年甚至更长的使用寿命。

#### SMARTER CONTROL UNIT

##### 更智能的控制系统

Future-oriented technologies with long-term availability and transformation. Powerful extending function for future challenges. C3 controller keeps you on top of processes that continue to become more and more complex.

面向未来的技术，C3控制器具备长期的可用性和改造性。强大的扩展功能迎接未来挑战，面对越来越复杂的工艺要求依然立于不败之地。



t-win Clamping Unit 锁模单元			t-win 4500	t-win 6500	t-win 8500	t-win 9500	t-win 10500	t-win 14000	t-win 16000	t-win 18000
Clamping force	锁模力	kN	4500	6500	8500	9500	10500	14000	16000	18000
Opening force with pressure pad	开模力 (高压油缸开模)	kN	260	370	510	620	620	760	1000	1000
Opening force with moving cylinder	开模力 (移模油缸开模)	kN	156	192	192	284	284	284	393	393
Opening stroke	开模行程	mm	1050	1350	1400	1600	1600	1800	2350	2350
Mold height min	最小模厚	mm	350	400	450	500	500	600	700	700
Mold height max	最大模厚	mm	850	950	950	1100	1100	1200	1400	1400
Total daylight max.	最大模板间距	mm	1400	1750	1850	2100	2100	2400	3050	3050
Platen size hor. x vert.	模板尺寸 (水平x垂直)	mm	1075x1175	1380x1320	1480x1380	1630x1610	1630x1610	1870x1960	2290x2130	2290x2130
Distance between tie bar hor. x vert.	拉杆间距	mm	810x800	1040x910	1120x960	1270x1100	1270x1100	1470x1360	1680x1520	1680x1520
Mold weight max.	最大模具重量	kg	6500	9500	11000	13000	13000	21000	30000	30000
Ejector stroke	顶针行程	mm	250	250	300	300	300	300	300	300
Ejector force forward/return	顶针力 前进/后退	kN	105/51	105/51	195/92	230/108	230/108	260/123	260/123	260/123
Dry operation (Euromap 6) time	干周期 (欧规6)	sec	3.1	3.7	4.0	4.6	4.6	5.1	5.7	5.7
Dry operation (Euromap 6) stroke	干周期开模行程 (欧规6)	mm	550	700	750	850	850	1000	1150	1150
Weight CU	锁模单元净重	t	11	15	19	28	28	44	56	56

t-win Injection Unit 注射单元			2000			3300			4800			7000			11000			15000			
Screw diameter	螺杆直径	mm	55	60	70	60	70	80	70	80	90	80	90	105	90	105	120	105	120	135	150
Screw stroke	注射行程	mm	330	350	350	360	420	430	420	480	480	480	540	550	540	630	630	630	720	730	730
Injection capacity	注射容积	cm <sup>3</sup>	784	990	1347	1018	1616	2161	1616	2413	3054	2413	3435	4762	3435	5455	7125	5455	8143	10449	12900
Shot weight (PS) <sup>①</sup>	注射量 (PS) <sup>①</sup>	g	721	910	1239	936	1487	1989	1487	2220	2809	2220	3161	4381	3161	5019	6555	5019	7492	9613	11868
Screw speed	螺杆转速	min <sup>-1</sup>	220			200			160			140			120			90			
L/D ratio	长径比	L/D	22			22			22			22			22			22			
Plasticizing rate (3 zones) <sup>①</sup>	熔胶率 (三段式螺杆) <sup>①</sup>	g/s	40.0	49.9	74.2	45.3	67.5	92.4	54.0	73.9	101.8	64.7	89.1	132.7	76.4	113.7	159.5	85.3	119.6	161.4	210.8
Injection rate max. <sup>②</sup>	最大注射速率 <sup>②</sup>	cm <sup>3</sup> /s	246	293	399	277	377	493	347	453	573	424	537	730	471	641	837	790	1031	1305	1612
Injection rate @ max. inj. Pressure	注射速率 (最大注射压力时)	cm <sup>3</sup> /s	188	223	304	204	277	362	258	337	426	327	414	563	388	528	690	563	735	930	1149
Injection pressure	注射压力	bar	1990	1730	1270	1940	1690	1290	1960	1710	1350	2020	1760	1290	1900	1650	1270	1860	1450	1150	930
Injection pressure max.	最大注射压力	bar	2300	2000	1469	2300	2000	1531	2300	2000	1580	2300	2000	1469	2300	2000	1531	2300	1800	1422	1152
Nozzle stroke	喷嘴行程	mm	600			600			800			800			800			800			
Nozzle contact force	喷嘴接触力	kN	110			110			150			150			150			150			
Heating wattage (incl. nozzle)	加热功率 (包括喷嘴)	kW	20	21	24	21	24	27	23	26	29	26	29	34	45	51	57	51	57	66	72
Heating zones (incl. nozzle)	加热区 (包括喷嘴)		5	6	6	6	6	6	6	6	7	6	7	7	6	6	7	6	7	7	8
Drive power SHV1/SHV2 <sup>③</sup>	驱动功率 SHV1/SHV2 <sup>③</sup>	kW	38/53			46/53			61/73			75(90 <sup>④</sup> )/90			90(115 <sup>⑤</sup> )/96			115/115			
Oil reservoir capacity	油箱容积	l	550			550			760			760(1150 <sup>④</sup> )			1150			1150			
Weight IU	注射单元净重	t	5.4			6			7.1			8(12.6 <sup>④</sup> )			13.1			14.5			

① Values for polystyrene 聚苯乙烯的值

② Theoretical values: at min. 80% injection pressure 理论值: (在) 最小80%注射压力下

③ SHV1 standard 标准 / SHV2 option 选配

Subject to technical alterations 以最新的技术变更数据为准

④ in combination with CU 1600 & 1800 与1600T及1800T锁模单元组合时

⑤ in combination with CU 2100 & 2400 与2100T及2400T锁模单元组合时



t-win Clamping Unit 锁模单元			t-win 21000	t-win 24000
Clamping force	锁模力	kN	21000	24000
Opening force with pressure pad	开模力 (高压油缸开模)	kN	1350	1600
Opening force with moving cylinder	开模力 (移模油缸开模)	kN	614	614
Opening stroke	开模行程	mm	3000	3000
Mold height min	最小模厚	mm	800	800
Mold height max	最大模厚	mm	1800	1800
Total daylight max.	最大模板间距	mm	3800	3800
Platen size hor. x vert.	模板尺寸 (水平X垂直)	mm	2520x2220	2680x2420
Distance between tie bar hor. x vert.	拉杆间距	mm	1920x1480	2020x1620
Mold weight max.	最大模具重量	kg	50000	62000
Ejector stroke	顶针行程	mm	400	500
Ejector force forward/return	顶针力 前进/后退	kN	385/168	420/184
Dry operation (Euromap 6) time	干周期 (欧规6)	sec	6.9	7.9
Dry operation (Euromap 6) stroke	干周期开模行程 (欧规6)	mm	1250	1400
Weight CU	锁模单元净重	t	80	88

t-win Injection Unit 注射单元			22000		
Screw diameter	螺杆直径	mm	135	150	160
Screw stroke	注射行程	mm	680	680	680
Injection capacity	注射容积	cm <sup>3</sup>	9733	12017	13672
Shot weight (PS) <sup>①</sup>	注射量 (PS) <sup>①</sup>	g	8954	11056	12578
Screw speed	螺杆转速	min <sup>-1</sup>	90		
L/D ratio	长径比	L/D	22		
Plasticizing rate (3 zones) <sup>①</sup>	熔胶率 (三段式螺杆) <sup>①</sup>	g/s	161.4	210.8	240.6
Injection rate max. <sup>②</sup>	最大注射速率 <sup>②</sup>	cm <sup>3</sup> /s	1335	1648	1875
Injection rate @ max. inj. Pressure	注射速率 (最大注射压力时)	cm <sup>3</sup> /s	1031	1272	1448
Injection pressure	注射压力	bar	2070	1677	1474
Injection pressure max.	最大注射压力	bar	2200	1850	1626
Nozzle stroke	喷嘴行程	mm	1100		
Nozzle contact force	喷嘴接触力	kN	150		
Heating wattage (incl. nozzle)	加热功率 (包括喷嘴)	kW	76	86	91
Heating zones (incl. nozzle)	加热区 (包括喷嘴)		7	7	7
Drive power SHV1/SHV2 <sup>③</sup>	驱动功率 SHV1/SHV2 <sup>③</sup>	kW	2x78/2x95		
Oil reservoir capacity	油箱容积	l	1550		
Weight IU	注射单元净重	t	19.6		

① Values for polystyrene 聚苯乙烯的值

② Theoretical values: at min. 80% injection pressure 理论值: (在) 最小80%注射压力下

③ SHV1 standard 标准 / SHV2 option 选配

Subject to technical alterations 以最新的技术变更数据为准

t-win Injection Unit 注射单元	2000	3300	4800	7000	11000	15000	22000
Screw Diameter 螺杆直径 mm	55 60 70	60 70 80	70 80 90	80 90 105	90 105 120	105 120 135 150	135 150 160
t-win 4500							
t-win 6500							
t-win 8500							
t-win 9500							
t-win 10500							
t-win 14000							
t-win 16000							
t-win 18000							
t-win 21000							
t-win 24000							

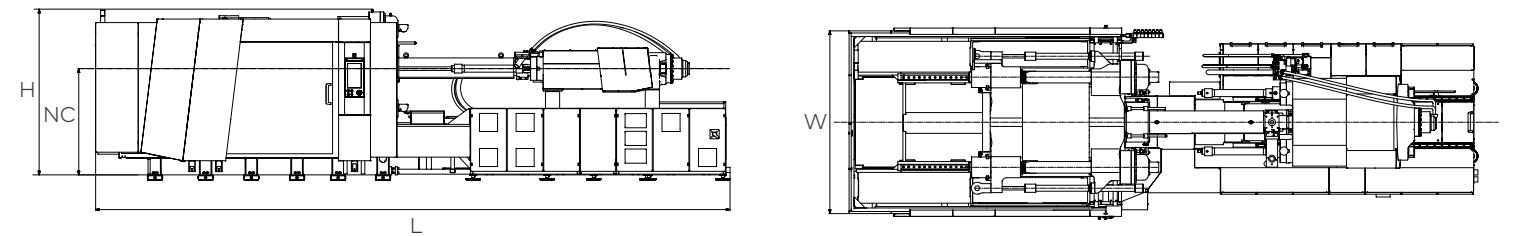

t-win Machine Dimensions 机器尺寸					
锁模单元 CU	注射单元 IU	长 L mm	宽 W mm	高 H mm	喷嘴中心高度 NC mm
t-win 4500	2000/3300	7200	2300	2400	1400
t-win 6500	2000/3300 4800/7000	7600 8800	2700	2400	1400
t-win 8500	3300 4800/7000 11000	7700 8900 9900	2700	2400	1500
t-win 9500/t-win 10500	4800/7000 11000/15000	9400 10400	3000	2600	1500
t-win 14000	4800/7000 11000/15000	9800 10800	3100	2800	1700
t-win 16000/t-win 18000	7000 11000/15000 22000	11500 13050	3600	3100	1800
t-win 21000/t-win 24000	11000/15000 22000	13450 14620	4250	3400	2000

4500 kN

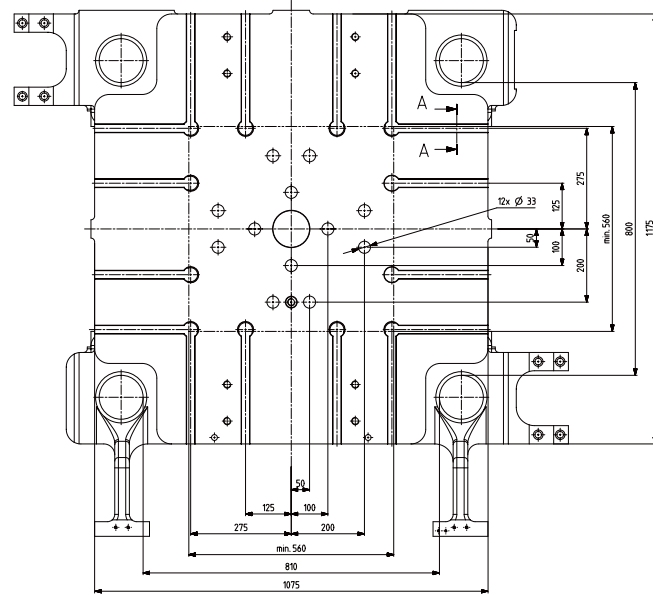

6500 kN

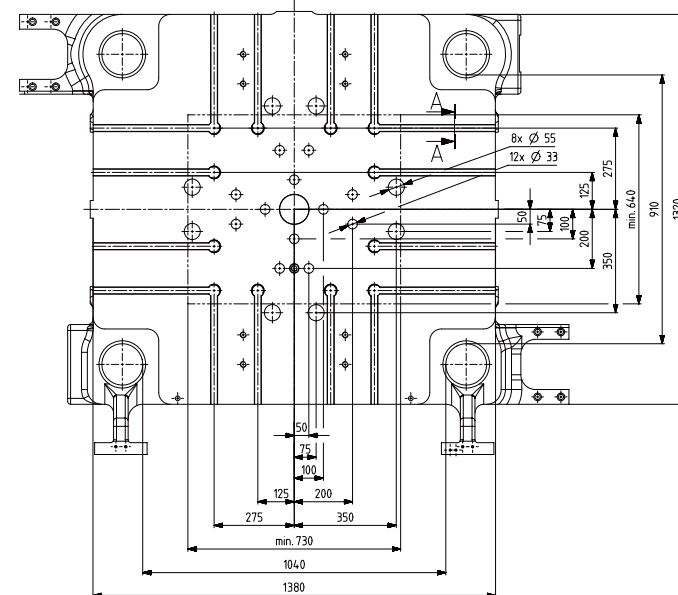

14000 kN

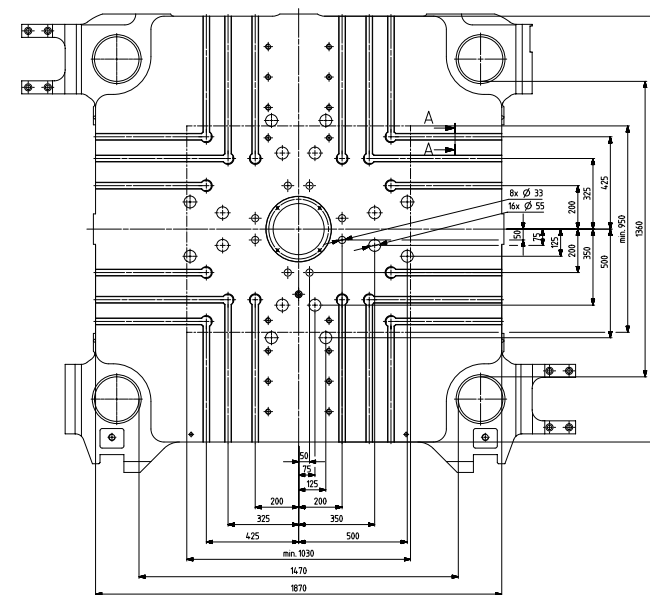

16000/18000 kN

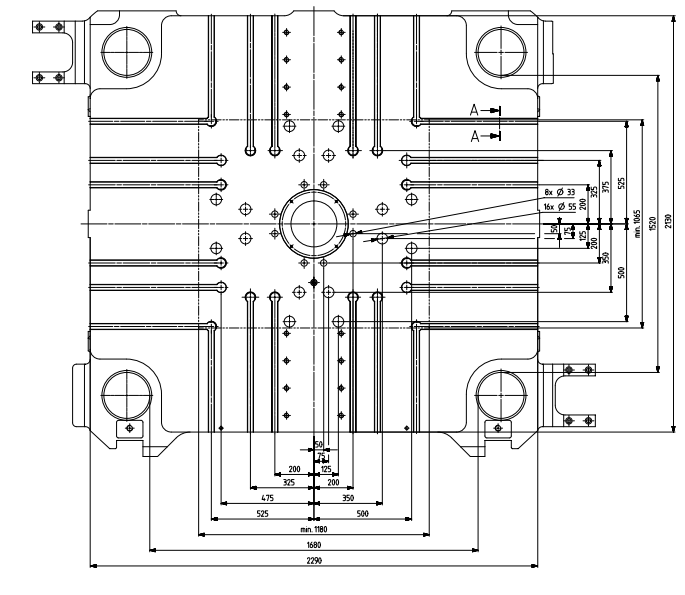

8500 kN

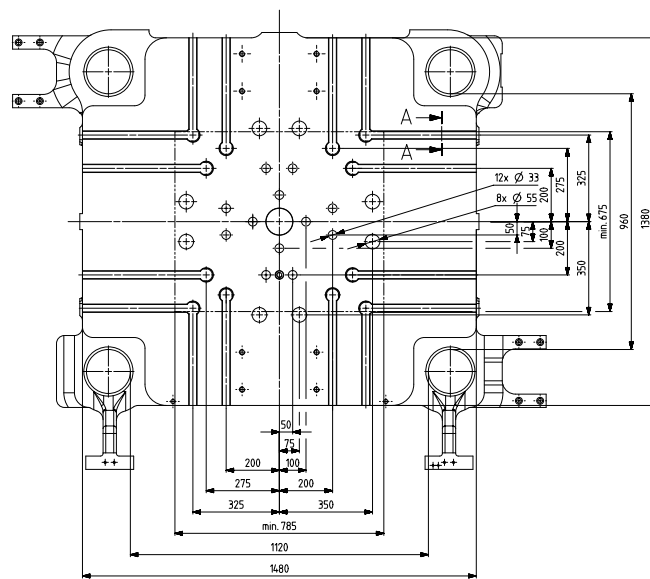

9500/10500 kN

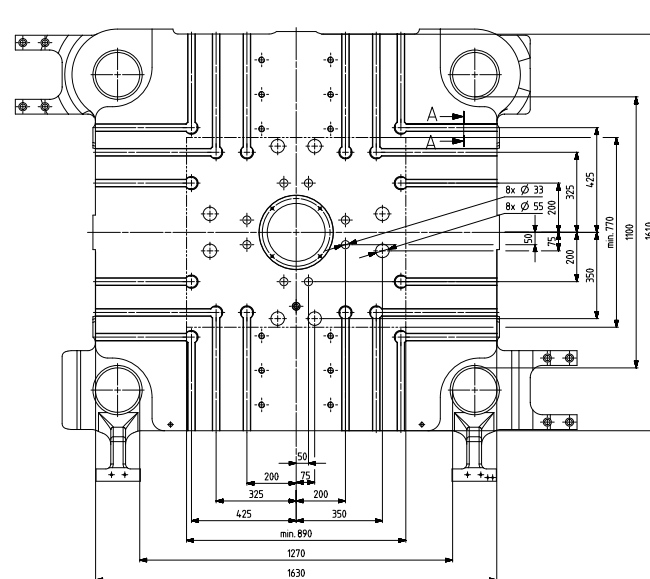

21000 kN

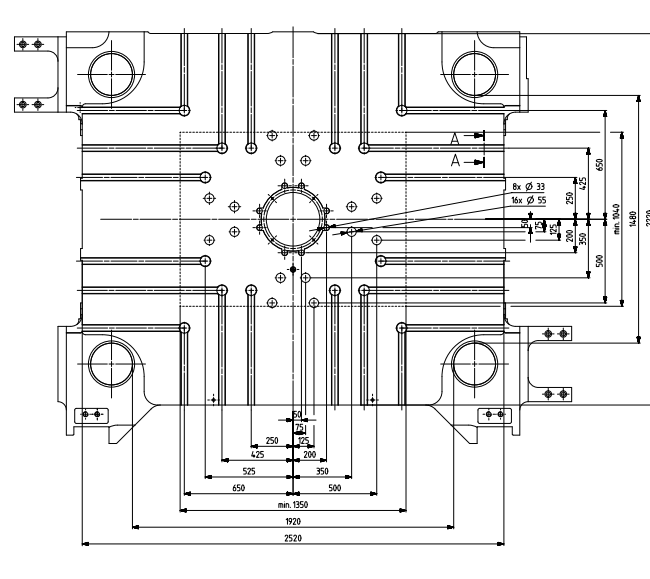

24000 kN

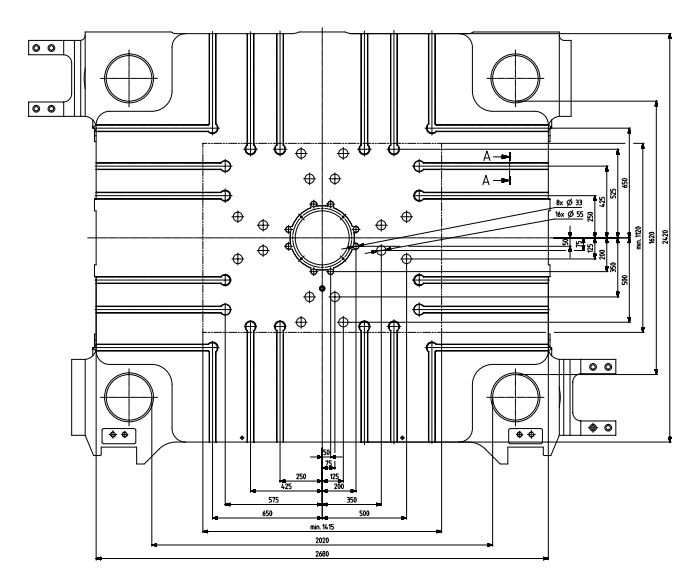

# WINTEC

MEMBER OF THE ENGEL GROUP

