

## Logistics

Cutting-edge injection molding solutions



Website



LinkedIn

ENGEL MACHINERY (CHANGZHOU) CO., LTD.  
No. 9 Longfan Road, Wujin National Hi-Tech Industrial Zone,  
Changzhou 213166, Jiangsu Province, P.R. China  
tel: +86 519 8159 5300  
e-mail: info@wintec-machines.com



**WINTEC, as a member of the ENGEL group, give you your competitive edge competing in the Challenging Logistics Industry.**

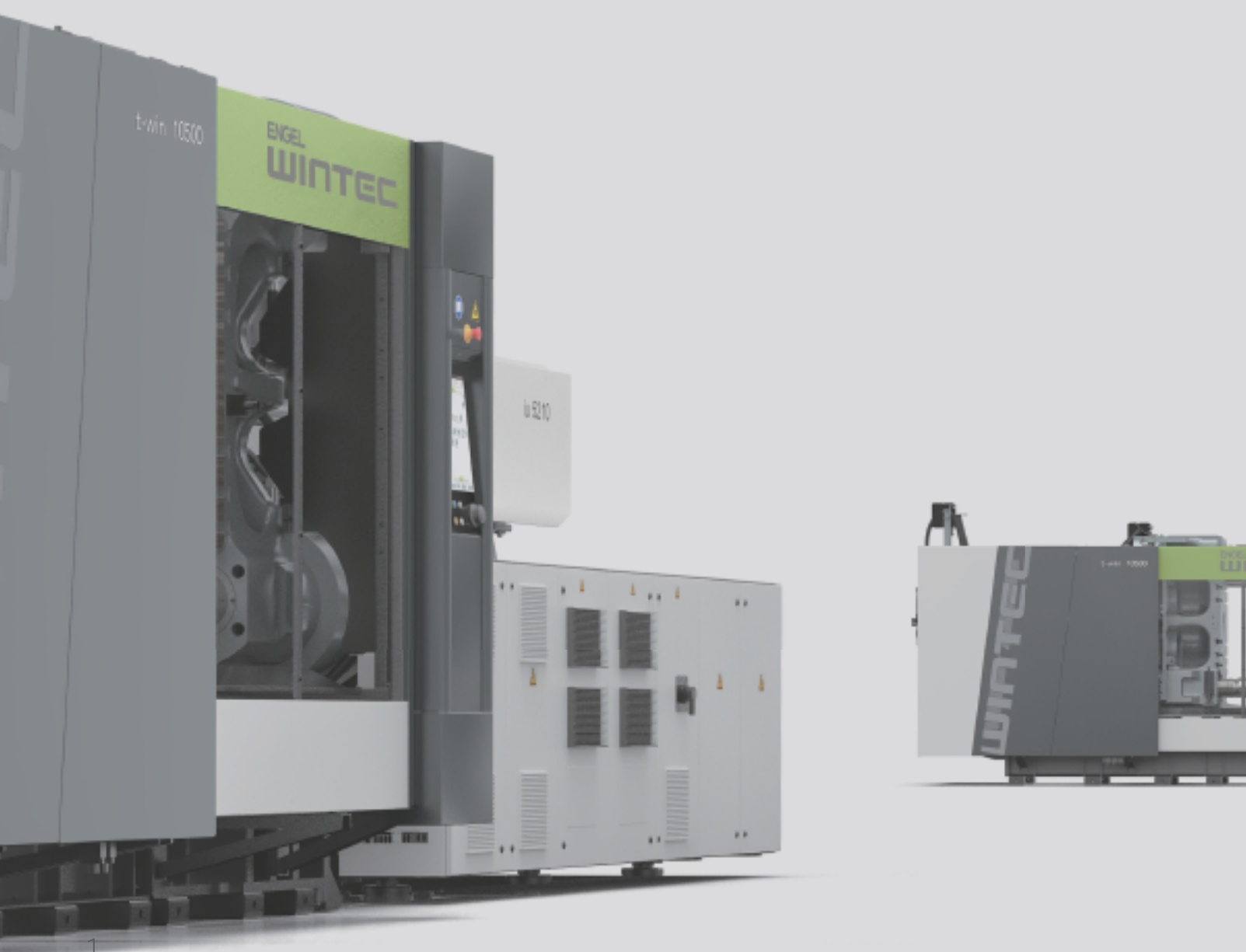

In logistics, the trend is moving strongly towards plastic solutions for large and durable products such as crates & boxes, pallets and containers for food and nonfood applications. Plastics offer clear advantages over wood and cardboard: they are easy to clean, stable in shape, less prone to damage, and highly hygienic. By combining the strengths of other materials while avoiding many of their weaknesses, plastics have become the preferred choice for modern logistics.



Injection molding in the logistics sector must meet three key demands: fast delivery, consistent quality, and controllable costs. Meeting all three is already a major challenge. At the same time, customers expect high flexibility which require flexible solutions capable of running different products.



## The ideal machine concept for your logistics applications

### t-win

With WINTEC t-win hydraulic two platen machine, you will receive stability, precision, efficiency with an optimal total cost of ownership, to realize the advantage of high output, consistent part quality, and maximum machine availability over your competition in the logistics industry.

Clamping Unit (kN)	Injection Unit Screw Diameter (mm)	1510		2310		3510		5210		8210		11610		16610		22010		43210		56910										
		55	60	70	60	70	80	70	80	90	80	90	105	90	105	120	105	120	135	120	135	150	135	150	160	170	170	190	200	190
t-win 4500																														
t-win 6500																														
t-win 7500																														
t-win 9000																														
t-win 10500																														
t-win 14000																														
t-win 16000																														
t-win 18000																														
t-win 21000																														
t-win 24000																														
t-win 27000																														
t-win 32000																														
t-win 40000																														

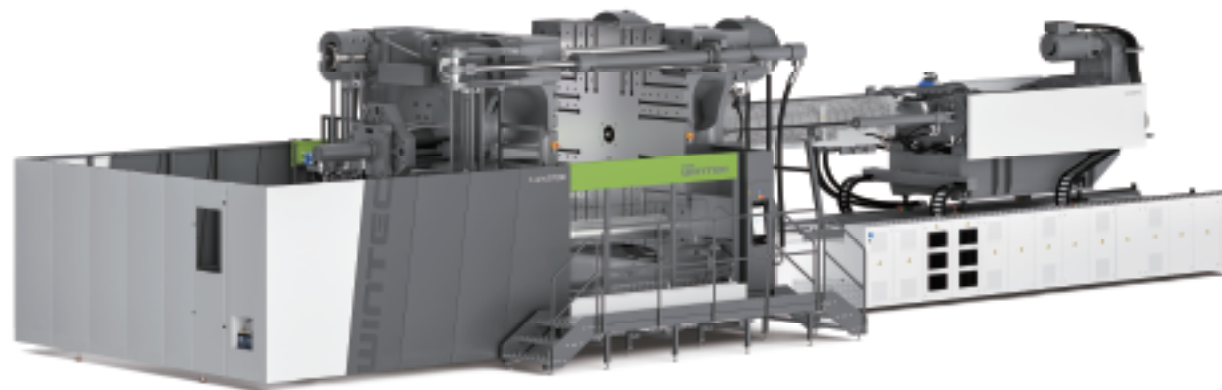

## Your advantages at a glance

### Higher Productivity

- The servo hydraulic two-platen t-win is focused on fast and high efficient production.
- Fast movements, short clamping force build-up time and synchronized locking device movement reduce total cycle time and increase productivity.

### Superior Stability

- Full-closed loop control design with accurate sensor and servowin drive to ensure the excellent stability on production.
- Excellent repeatability with high accuracy of mold opening and closing position.
- Logistics-specific plasticizing components response to the 100% recycled material processing.

### Smart Control Unit

- Smart control with rigorously validated ENGEL software design and technologies.
- Future-oriented technologies with long-term availability and transformation. Powerful extending function for future challenges. C3 controller keeps you on top of processes that continue to become more and more complex.

### Higher Energy Saving

- The low friction linear guide and contactless tie bar design ensure low energy consumption.
- The servo drive system servowin guarantees fast acceleration and remarkable energy efficiency.

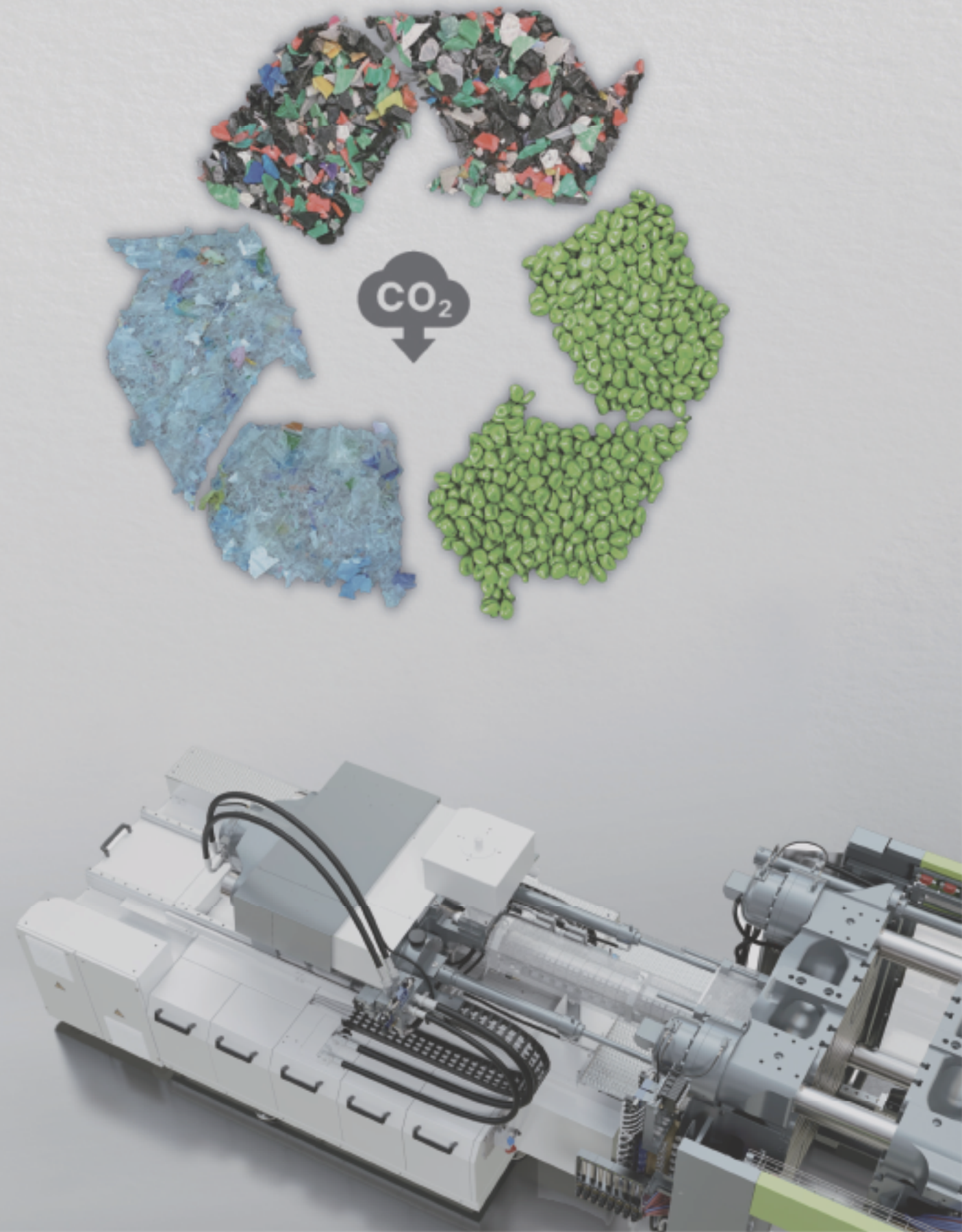

At WINTEC, we not only have the right products but also the necessary expertise – our market-tailored solutions enable efficient, high-performance production, guaranteeing your success.

# PLASTIC PALLET

## Strong, Sustainable, and Ready for High-Performance Logistics

Plastic pallets are vital in modern logistics, offering durability, hygiene, dimensional consistency, and recyclability. They are used in various systems like closed-loop, export, and automated warehouses, requiring high strength, low weight, and cost efficiency. Manufacturing these pallets via injection molding poses challenges:

- Large mold sizes
- High clamping forces
- Significant shot weights
- Recycled material

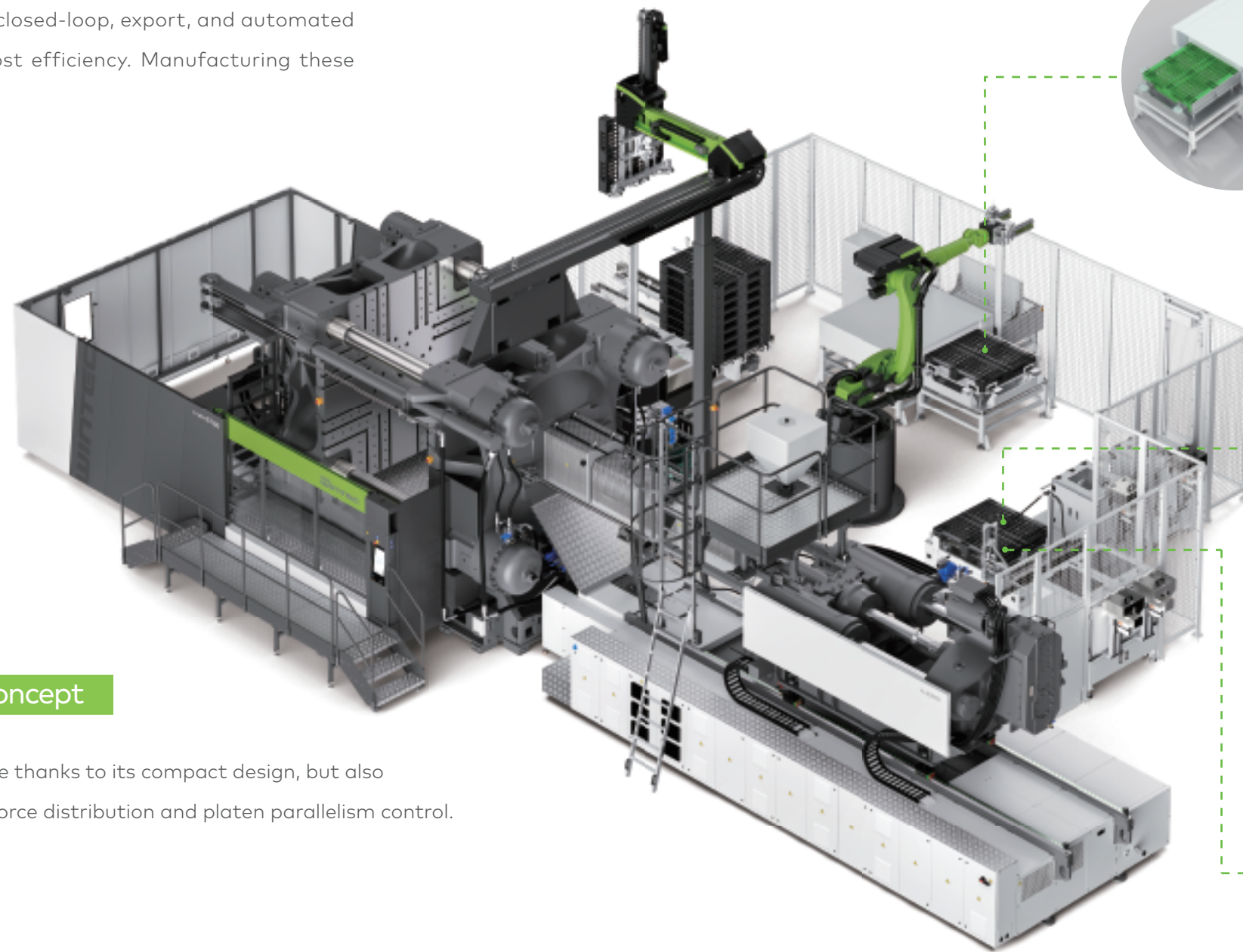
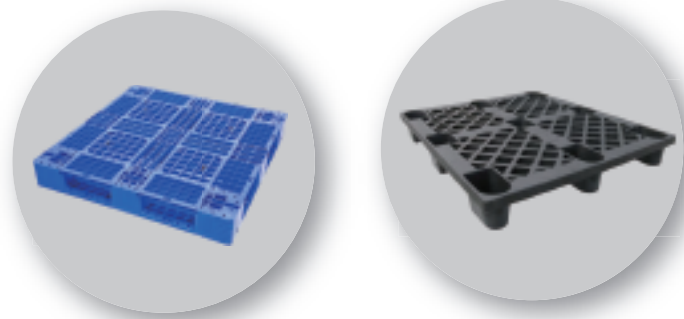

Automatic tube inserting station

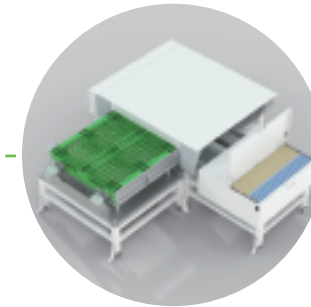

Station for inserting rubber pads



Automatic End cap & pin inserting station

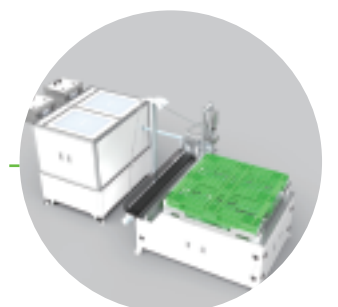

### Increased productivity through machine concept

The WINTEC t-win two-platen machine not only saves space thanks to its compact design, but also improves the part quality through the optimized clamping force distribution and platen parallelism control.

- Compact footprint
- Perfect platen parallelism

### Optimize your cycle time – rise your output

Parallel movements and increased flow rate on hydraulic core pulls allow faster movements of sliders and therefore reduce cycle time.

- SHV2 - Parallel movements
- High flow rate core pulls – fast motion

# CRATES AND BOXES

Efficient, Flexible, and Sustainable Production Solutions



Crates and boxes are essential components in modern logistics and intralogistics systems, serving diverse applications from agriculture to retail. The demand for versatile, high-performance products is growing, including beverage crates, ventilated fruit boxes, foldable containers, and storage bins. Manufacturers face challenges in producing a wide variety of sizes, types, and colors with maximum efficiency.

## Frequent mold changes – speed up your set up time

Stop manual efforts and find the right process setting automatically with our iQ products. WINTEC machines are capable to find automatically the right clamping force, plasticizing speed or holding pressure time.

## Maximize the output – accelerate the return on investment

Shortest dry cycle times and highest injection speeds (optional with accumulator) increase the output of your production cell.

## Reduce operating costs

Boost output while still saving running costs: thanks to optimum energy efficiency and minimum cooling water consumption, you can make your production far more profitable with WINTEC.

## Enhance productivity through automation

### Cooling station

Save cycle time with Cooling stations. Parts can be earlier demolded and finished in a separate cooling station. Due to the jigs, the part stays in shape and resist shrinking behaviour.



### Unloading and stacking station

Gripping the parts from different conveyors, sorting them and stacking in the right way, ready for pick up.



### Compact production cell for bottle crates

- Demolding by free falling crates and transferring out of the machine by conveyor.
- 4-side in-mold labelling inserted by linear robot.
- Inserting on 4-side soft grip handles.



# BIN

## High-Performance Molding for Demanding Applications



Bins are crucial components in waste management systems, designed for durability, stackability, and cost-efficiency. As production volumes increase, expectations for injection molding technology evolve, demanding solutions that ensure high output, process stability despite recycled material, energy efficiency, and flexibility while maintaining consistent quality.

### Save space

Despite high mold heights and deep cavities, the t-win stays compact with its two-platen design even when long opening strokes are required. As a result, you save space and can maximise your output per m<sup>2</sup>.

### Reduce material

The trend towards thinner walls for material savings demands fast injection speeds and high pressure. The WINTEC t-win machines are designed to achieve all at the same time: high speeds, high pressure and maximum flexibility in injection profiles.

### Improve your lid production

Avoid deformation and ensure accuracy with the active platen parallelism control and the uniform clamping force distribution of the WINTEC t-win machines.

## Upgrade your production with smart automation



### Labelling or branding

Put a company label or a customized tag on the bins by using hot stamping or printing technology.



### Reduce manual work

Use the available time of the take out robot and cut the sprues directly online in the production cell.



### Traceability

Apply a QR code by Laser technology or insert a RFID chip for full traceability of the bins.



### Save cycle time and demold faster

With a Cooling station with adjustable fixing elements, the form stability while post cooling can be guaranteed. Optional: active dimension adjustment through moving fixing elements.



### Save logistics efforts

Stack the bins directly in the production cell in the suitable height for later truck loading and prepare them for easy and convenient pick up by forklifts.

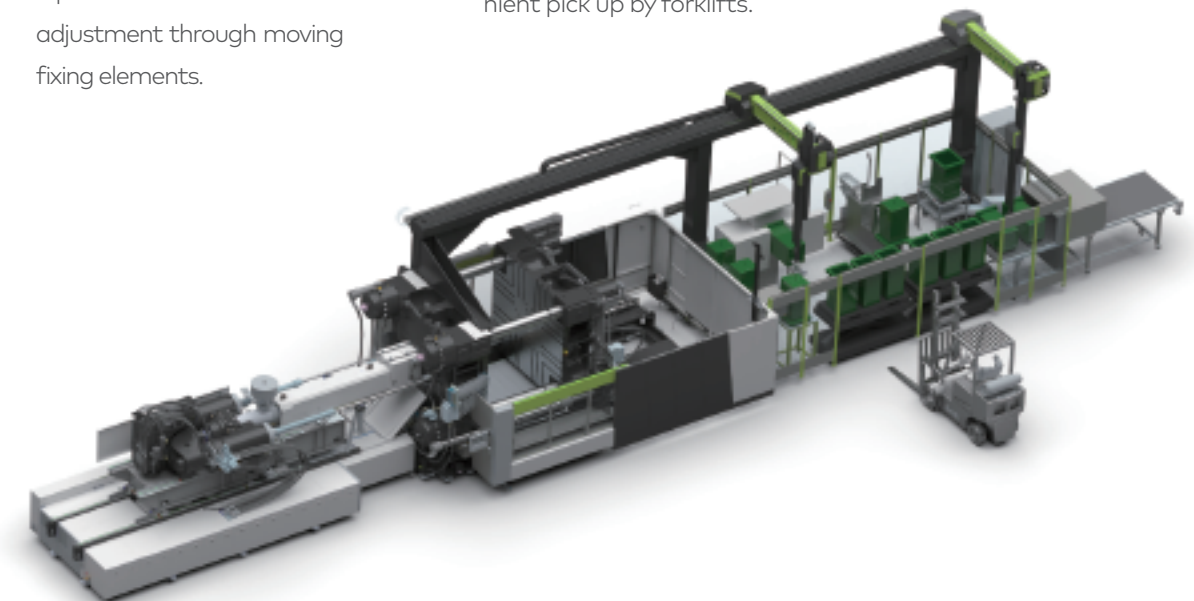

## Technology Highlights for Logistics applications

### More stable processes with recycle: Recycling package

The new recycling package is suitable for the trouble-free use of demanding recyclates (flakes and granulate). Geometrical adaptations on the plasticizing unit significantly improve the conveying and melting behaviour and thereby guarantee long lifetime through high wear resistant material.



### Sustainable logistics through lightweight parts – ENGEL foammelt

**Physical foaming:** Light-weight parts with a micro-foam inner structure. The physical foaming agent, nitrogen or carbon dioxide, is injected into the melt in a controlled manner and a homogeneous polymer-gas solution is formed through intensive mixing. The result is an integral foam structure consisting of a compact skin layer and a foamed core.



**Chemical foaming:** In chemical foaming a chemical blowing agent (CBA) in the form of powder or granules is added to the polymer. Our CBA package has been specially customized to the requirements of chemical foaming.

### Special Recycling technologies (applicable on ENGEL machine)

#### ■ ENGEL skinmelt and co-Injection

Surface quality, colour requirements or smell can be reasons why the usage of virgin material is mandatory. With the ENGEL skinmelt or co-Injection processes, it is possible to combine two different materials in one injection process. Per example, virgin material on the part surface while recycled material in the core of the part.

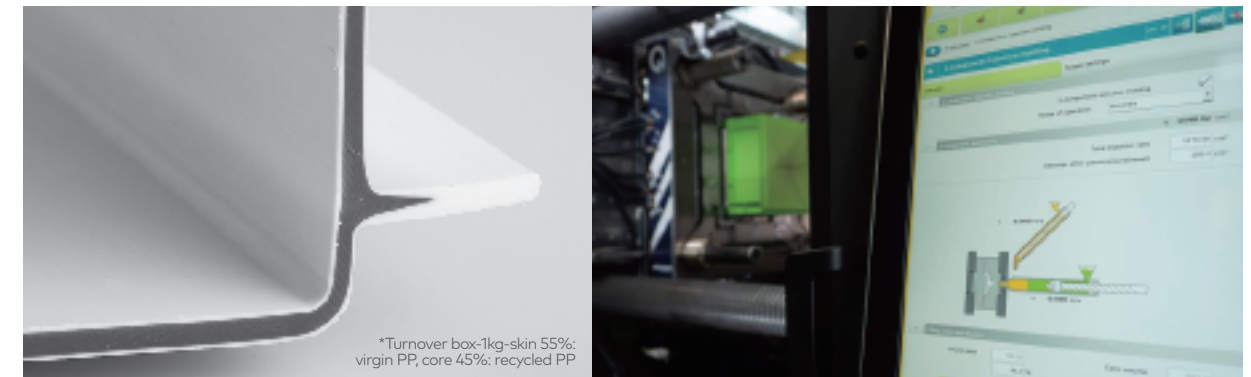

#### ■ Two-stage process

When recyclates have contaminations that are too large for processing on normal injection moulding machines, the ENGEL two-stage process is the answer. This technology is characterised by a concept with 2 stages. One for continuous pre-plasticising, one for injection.

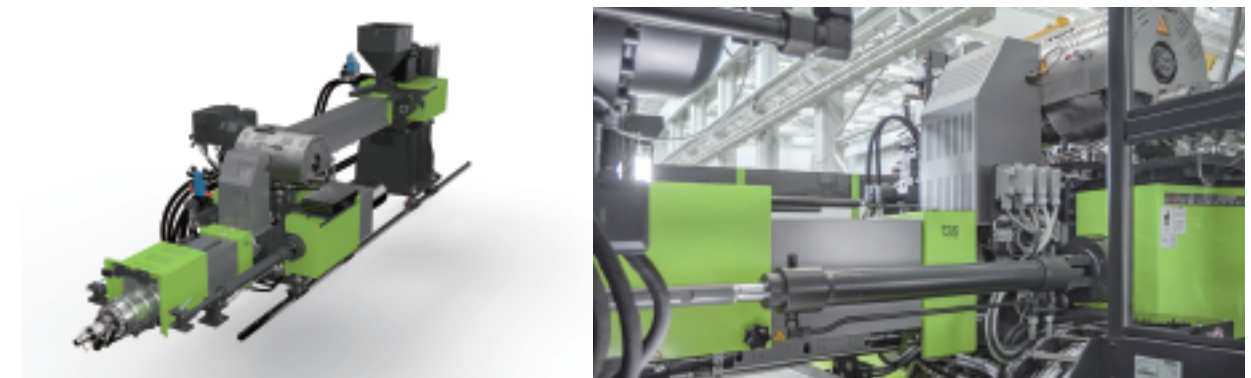



## About WINTEC

As a member of the ENGEL group, WINTEC is committed to creating high-quality and efficient injection moulding machines and solutions, that shatter the impossible trio of quality, efficiency, and cost, making it a reliable partner for your successful international development.



### Powered by ENGEL

By harnessing ENGEL's 80 years of engineering mastery and global sales and service network, we turn industry-leading performance into your competitive advantage.

### Adapted to streamline

Adapting rigorously validated ENGEL technologies, we bring the injection molding process straightforward, hassle-free and deliver smart, simple and effective solutions.

### Industry solutions

Every machine we build, every solution we design is driven by a deep understanding of your challenges, and what it takes to realize your ambitions in winning the battle in your industry.

